

# AQUILO

Radiant Metal Ceiling A11 + Aquilo



## QUICK FACTS

- Thermal comfort according to EN ISO 7730
- Very high heating and cooling capacity: heating up to  $104 \text{ w/m}^2$  (15 K), cooling up to  $103 \text{ w/m}^2$  (8 K)
- Active concrete management
- Free of draught air according to EN ISO 7730, classes A/B
- Superior acoustic properties:  $\alpha_w$  up to 0,90
- Sound power level  $L_w$ : < 25 dB (A)
- Functions
  - Cooling
  - Heating
  - Mass connection
  - Acoustics
  - Supply and exhaust air
  - Integral components

# Technical description

## General

The radiant metal ceiling A11 + Aquilo is a powerful climate ceiling system with integrated supply air and superior acoustic effectiveness. The integrated supply air element create a high ventilation efficiency. At the same time, the supply air jet on the back of the ceiling panel increases the convective output, which enhances the heating and cooling effect in the room without any risk of draughts. According to the principle of the thermoactive component system, it also includes the storage mass for the dissipation of heat loads in the overall room thermal concept.

## Activation

Water system: The radiant ceiling is a passive system that in the case of cooling absorbs heat from the room via the ceiling surface, transfers it to the water, which is conducted in activation registers, and dissipates it, respectively emits heat in the case of heating.

The activation of the radiant metal ceiling system A11 consists of meandering copper pipes (outside diameter 12 mm) and aluminum heat-conducting rails (width 80 mm), which are connected by laser spot welding and glued into the ceiling panels.

## Functions

The radiant metal ceiling A11 + Aquilo is multifunctional. In addition to the thermal functions of cooling/heating and the active concrete management, there is the possibility of further integration: acoustically effective inserts or baffles (Archisonic®), various built-in components (e.g. smoke detectors, lighting).

## Combinations

- Radiant Metal Ceiling System A11 + Archisonic®

## Hygiene conformity

- Hygiene conform to VDI 6022 / SWKI VA104-01

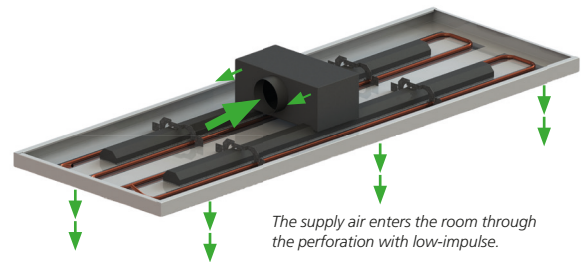

Type 2 channel with flow characteristic of the supply air.

# Technical data

## Capacity

Initial data is presented below.

Systems compared (with edge joint)	Radiant metal ceiling A11 + Aquilo ——①	Radiant metal ceiling A1 ----②
Material	Steel	Steel
Perforation	Rg 1,5 – 11 %	Rg 1,5 – 11 %
Activation method	on metal	on metal
Acoustic inlay	Fleece	Fleece
Additional inlay	without	without

(Capacity information without project-specific performance-influencing factors.)

EN 14240:2004

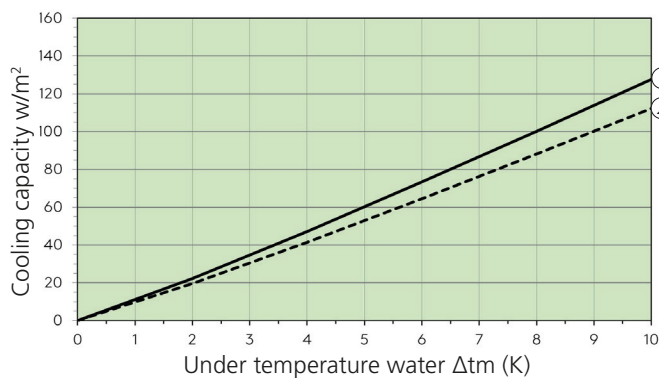

EN 14037:2016

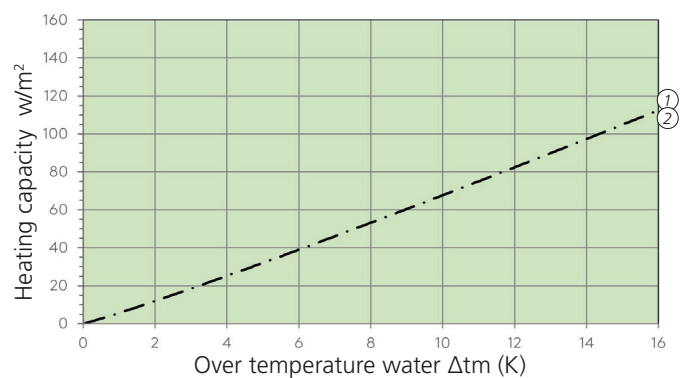

Version	<sup>1)</sup> Cooling 8 K	<sup>1)</sup> Cooling 10 K	Heating 15 K
① Radiant metal ceiling A11 + Aquilo	up to 103 w/m <sup>2</sup>	up to 127 w/m <sup>2</sup>	up to 104 w/m <sup>2</sup> (---·---)
② Radiant metal ceiling A11	up to 90 w/m <sup>2</sup>	up to 112 w/m <sup>2</sup>	up to 104 w/m <sup>2</sup> (---·---)

<sup>1)</sup> Depending on the configuration, an additional output of 10 w/m<sup>2</sup> of panel area is achieved through concrete management.

### Notice

- SN EN 14240: The cooling capacity is related to the active area according to SN EN 14240:2004. The active area is calculated according to SN EN 14240 from the number of heat-conducting rails x length of heat conducting rail x distance between heat conducting rails.
- SN EN 14037: The heating capacity is related to the active area according to SN EN 14037:2016. The active area is calculated according to SN EN 14037 from the length of the ceiling panel x the width of the ceiling panel.

## Operation

### Supply air volume flow maximum per linear meter

Aquilo	6 K	8 K	10 K	12 K
Type 1 channel	35 m <sup>3</sup> /h	34 m <sup>3</sup> /h	32 m <sup>3</sup> /h	30 m <sup>3</sup> /h
Type 2 channels	70 m <sup>3</sup> /h	68 m <sup>3</sup> /h	64 m <sup>3</sup> /h	60 m <sup>3</sup> /h

### Water (recommendations)

- Temperature
  - Cooling 16 – 18 °C
  - Heating 28 – 37 °C
- Pressure drop: 20 – 25 kPa
- Water flow: 80 – 150 l/h
- Max. operating pressure up to 9 bar
- Water quality according to: SWKI BT 102-01, BTGA 3.003, VDI 2035

## Acoustics

### Diagram for calculating sound power level $L_{WA}$ and pressure drop

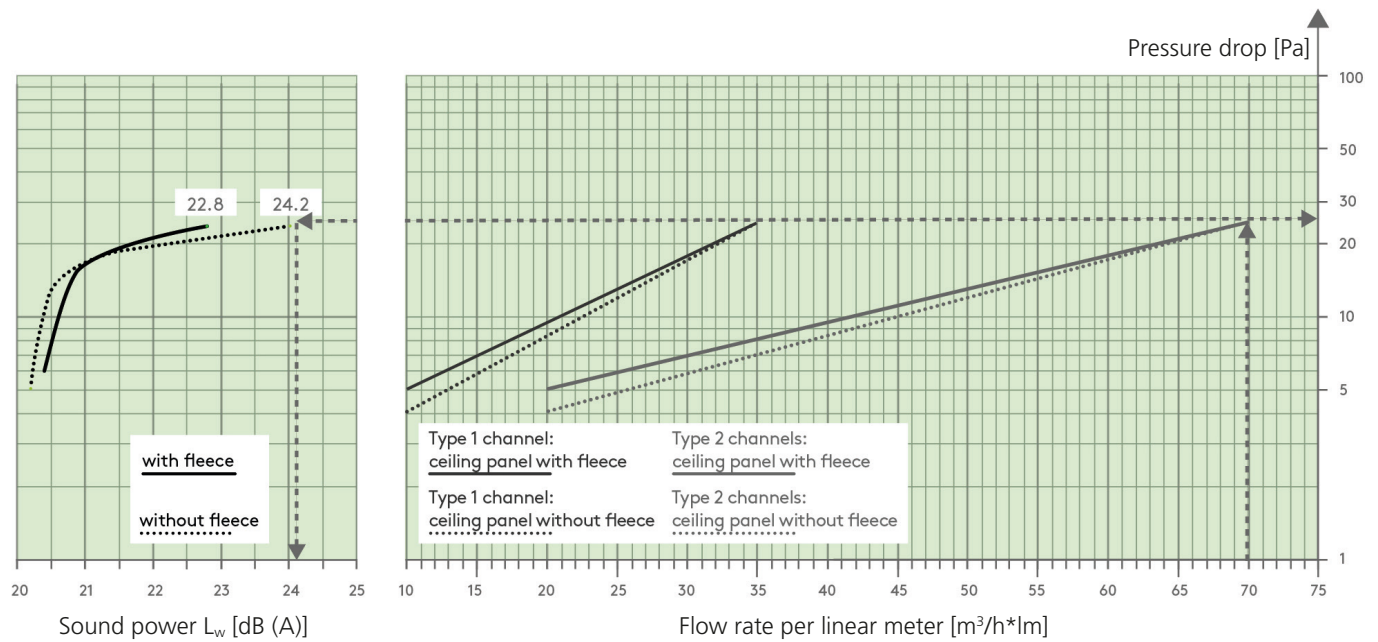

### Insertion attenuation $D_t$ in octave band

Centre frequency $f$ in [Hz]	63	125	250	500	1000	2000	4000	8000
$D_t$ with fleece in [dB]	25,9	17,6	13,7	13,7	10,7	10,6	7,2	6,7
$D_t$ without fleece in [dB]	26,9	17,8	13,9	14,0	10,6	11,3	7,6	7,6

All sound insertion attenuation tests were carried out by the Fraunhofer Institute for Building Physics in accordance with EN ISO 7235 (IBP Report P-TA 26/2016). The relevant insertion attenuation is calculated from the sound power values with and without Aquilo radiant sails.

### Sound absorption according to EN ISO 11654

Ceiling panel	Soundabsorption value $a_w$	Sound absorption class
with acoustic fleece without acoustic strips	0,65	C
with acoustic fleece with acoustic strips version 1	0,80	B
with acoustic fleece with acoustic strips version 2	0,85	B
with acoustic fleece with acoustic strips version 3	0,90	A

Initial data: values at installation high 200 mm.

# System

## Ceiling system

- Ceiling closed (with edge joint)
  - Rectangular panels

## Installation systems

- Installation height:
  - Type 1 channel min. 115 mm
  - Type 2 channels min. 150 – 200 mm
- Lay-in system
- Hook-on system
- C-channel systems

## Types Aquilo

- Type 1 channel

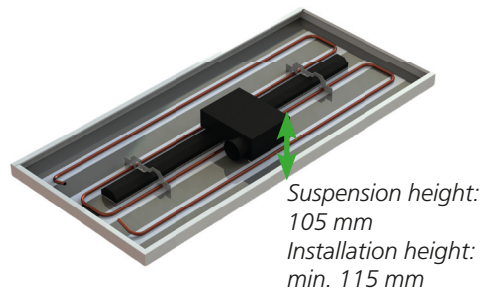

- Type 2 channels

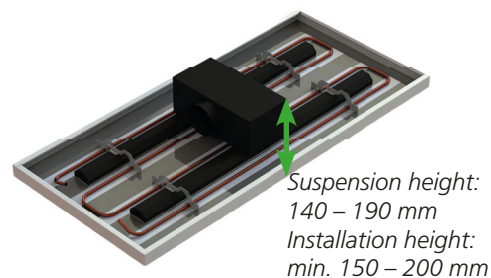

# Materials, weight and dimensions

## Materials and weight

Material ceiling panel	Weight ceiling panel (incl. activation, water)	Weight supply air element Aquilo (Steel sheet)
Aluminium 1,00 mm	4,0 – 6,5 kg/m <sup>2</sup>	4,0 – 6,0 kg/piece
Steel 0,70 mm	6,5 – 9,0 kg/m <sup>2</sup>	

Building material class: A2-s1, d0, EN 13501-1 (depending on the acoustic solution).

## Dimensions ceiling panel construction

Dimensions standard	Type 1 channel	Type 2 channel
Panel width	310 – 1200 mm	600 – 1200 mm
Panel length	1000 – 2500 mm	1000 – 2500 mm
Panel height <sup>(1)</sup>	50 – 120 mm	50 – 120 mm
Suspension height (Minimum height 50 mm ceiling panel edge)	105 mm	140 – 190 mm <sup>(2)</sup>

<sup>1)</sup> Standard: Panel edge height 50 mm, angle of bend right angle / <sup>2)</sup> Special versions possible from 105 mm.

## Dimensions supply air connection

Air channel (mm)	800	900	1000	1100	1200	1300	1400	1500
Type 1 channel Ø DN (mm)	80	80	80	80	80	100	100	100
Type 2 channels Ø DN (mm)	100	100	100	125	125	125	125	125

## Surface

### Versions

- Powder coating
- Digital printing on request

### Colors

- Standard RAL 9010
- Other RAL / NCS colors on request

### Perforations

- Standard perforations
- Other perforations on request

Standard perforations:

Rd 1,5 – 11 %

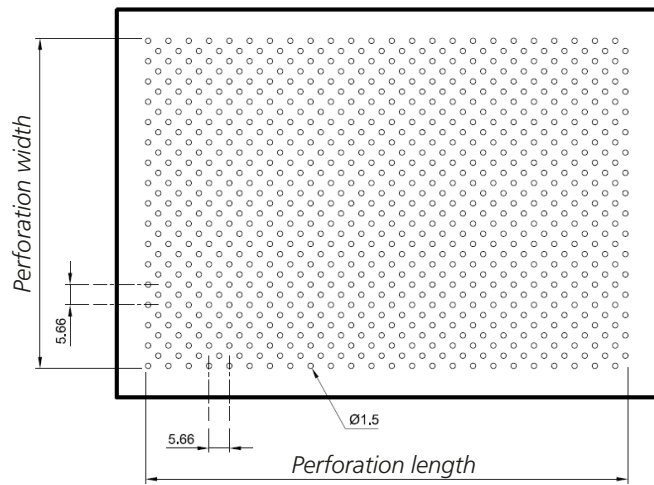

Rg 1,5 – 11 %

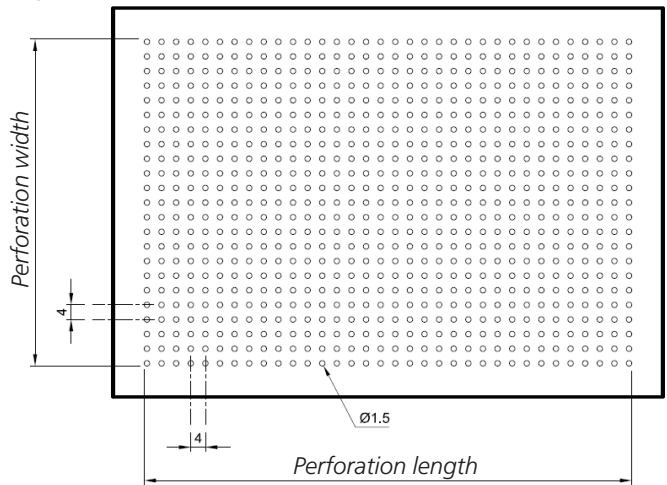

Rd 1,5 – 22 %

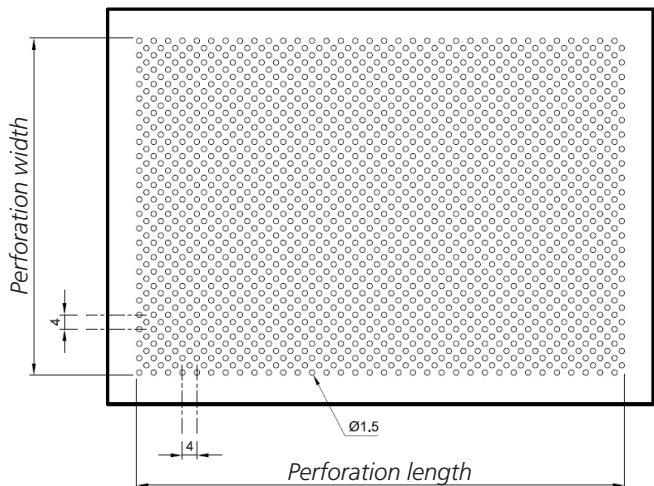

Rg 2,5 – 16 %

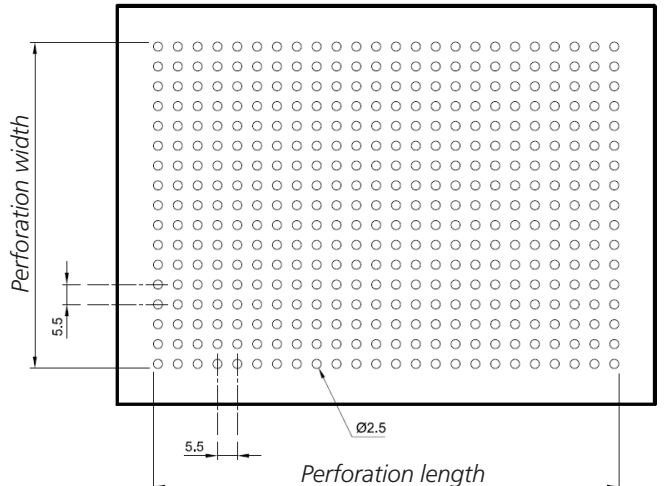

## International

### Barcol-Air Group AG

Wiesenstrasse 5  
8603 Schwerzenbach  
T +41 58 219 40 00  
F +41 58 218 40 01  
info@barcolair.com

## Switzerland



### Barcol-Air AG

Wiesenstrasse 5  
8603 Schwerzenbach  
T +41 58 219 40 00  
F +41 58 218 40 01  
info@barcolair.com

### Barcol-Air AG

Via Bagutti 14  
6900 Lugano  
T +41 58 219 45 00  
F +41 58 219 45 01  
ticino@barcolair.com

## Germany

### Barcol-Air GmbH

Bahnhofstrasse 39  
21614 Buxtehude  
T +49 4161 800 28 0  
F +49 4161 800 28 20  
verkauf-deutschland@barcolair.com

## France

### Barcol-Air France SAS

Parc Saint Christophe  
10, avenue de l'Entreprise  
95861 Cergy-Pontoise Cedex  
T +33 134 24 35 26  
F +33 134 24 35 21  
france@barcolair.com

## Italy

### Barcol-Air Italia S.r.l.

Via Leone XIII n. 14  
20145 Milano  
T +41 58 219 45 40  
F +41 58 219 45 01  
italia@barcolair.com